

PATCHING MATERIALS

Self Adhesive Patch Up Tape



- Supplied in 4 thicknesses - 35, 55, 75 and 90 microns
- 6mm width
- 20 metres per roll

Shim Tape



- 10 or 30 metres rolls
- .001" (25 microns), .002" (50 microns), .005" (125 microns)
- Steel strip for durability; will not compress

Triplex Patch Sheet



- Calibrated for accuracy
- Totally no tear
- Moisture resistant
- Roll size 1200mm x 50m

Carbon Paper



- For making patch up sheets
- Roll size 1200mm x 900m

COUNTERS

Countamat

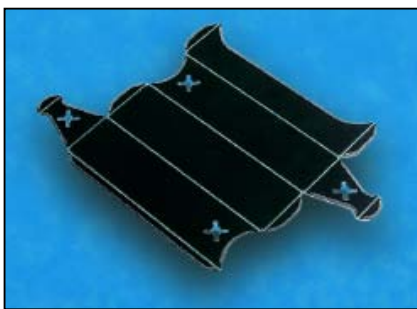

- High quality durable counter material
- Developed by Channel for clean routing yet long run durability
- 1070 x 1040 sheet
- with or without backing adhesive

Counter Locating Pins



- For location of counters

Ejectors

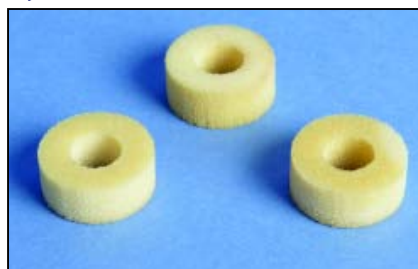

- Ejector for the pertinax locating pin

ADHESIVES

ER-1500



- Cyanoacrylate adhesive for flat bed dies
- 5 second dry time to position rubber
- 50g bottles

FS-100



- Cyanoacrylate adhesive for rotary dies
- Instant dry
- 50g bottles

TOOLS

Pneumatic Nick Grinder



- ▶ 70psi operation
- ▶ Direct drive - no belts!
- ▶ Cutting depth regulator

Electric Nick Grinder



- ▶ Direct drive - no belts!
- ▶ Cutting depth regulator
- ▶ 240v or 110v electric motor

Metal Mitring Pliers



- ▶ Cuts 45° mitred angles
- ▶ Fits all matrix base widths
- ▶ Spare blade included
- ▶ Plastic handle pliers also available

Multi Cutter



- ▶ Cuts matrix and ejection rubber
- ▶ Replaceable blade
- ▶ Safety locking feature

Supercut 2 Matrix Cutter

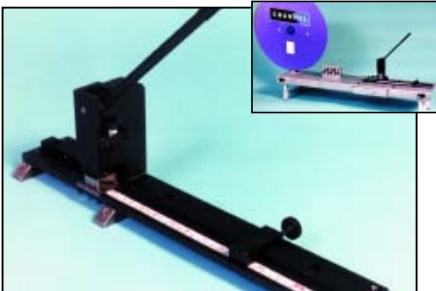

- ▶ Mitres both ends with one cut
- ▶ Suits all widths of matrix and centres automatically
- ▶ Punch type cutting tool
- ▶ Waste ejects below machine
- ▶ 45° & 60°

TOOLS

Nicking Discs

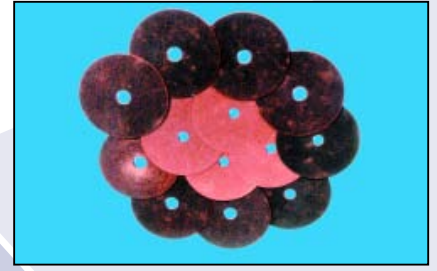

- ▶ A type: 50mm OD x 6mm ID
- ▶ B type: 50mm OD x 8mm ID
- ▶ Mini: 35mm OD x oval ID

Nicking Chisels



- ▶ Available in widths of 0.4, 0.5, 0.6, 0.7, 0.8, 0.9 and 1.0mm

Rule Extractor



- ▶ Remove rule easily
- ▶ No damage to dieboard
- ▶ Moveable peg feet for tight areas
- ▶ Spare jaws available

Rule Straightener



- ▶ Hand held tool

Sliding Gauge

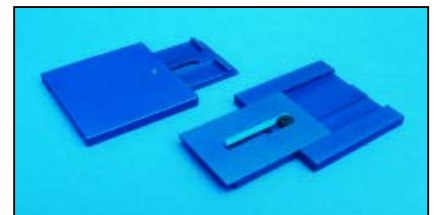

- ▶ To position board on hand platens
- ▶ Self adhesive back

STRIPPING FORME ACCESSORIES

New Bobst Storage Spacer

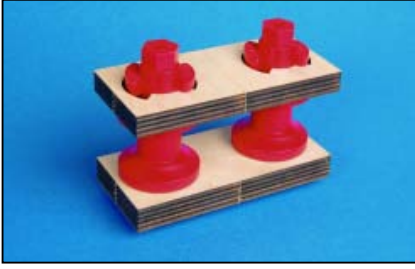

- ▶ One piece construction
- ▶ New screws necessary
- ▶ Locks male and female dieboard securely



New Bobst Centring Block

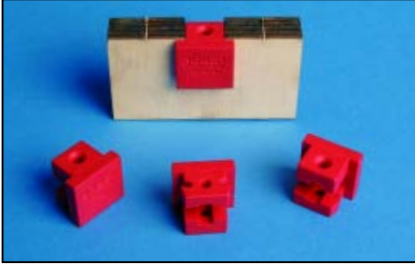

- ▶ Easy Assembly
- ▶ No screws - just push into die

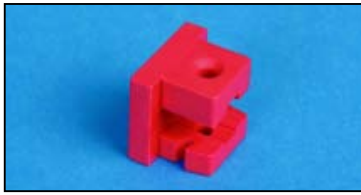

Centring Piece



- ▶ Now available in plastic



Centreline 1



Centreline 2

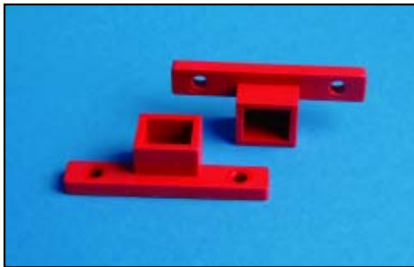

Bobst Nut and Bolt



- ▶ Available in 43mm or 50mm heights
- ▶ Reinforced plastic material for strength

Distance Spacers



- ▶ For the male (upper) stripping forme
- ▶ 23, 25 or 28mm inner barrel
- ▶ 45mm overall length

STRIPPING FORME ACCESSORIES

Rear Clamp Block



- ▶ Integral metal threaded nut
- ▶ More cost effective than metal type; no need to remove

Alu Profile



- ▶ For SPO stripping formes
- ▶ 80 x 50 x 30mm, holes every 40mm
- ▶ 100 x 50 x 30mm, holes every 50mm, notched both sides

Separating Knife

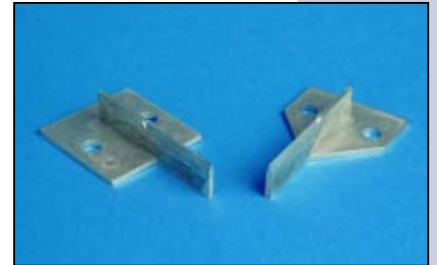

Star Nails



- ▶ X shaped stripping pin
- ▶ 50mm length

STRIPPING FORME ACCESSORIES

Pinpoint

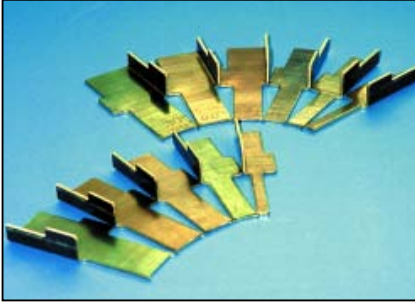

- ▶ Cost effective stripping system
- ▶ Reduces bottom pins dramatically
- ▶ Reduces make ready times on and off press
- ▶ Does not compromise machine speed
- ▶ Good longevity
- ▶ Operator friendly
- ▶ Widths of 4, 6, 8, 10, 12 and 14mm
- ▶ Packed in 100 left hand and 100 right hand per box

ILLUSTRATED POSITION OF THE STRIPPERS

Inside Waste

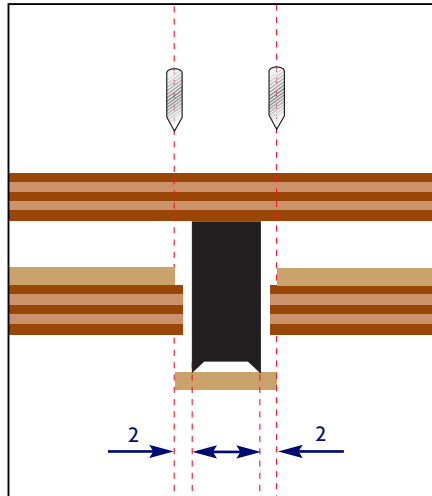

New Reinforcement Bar



- ▶ Slots into dieboard
- ▶ No brackets or screws necessary

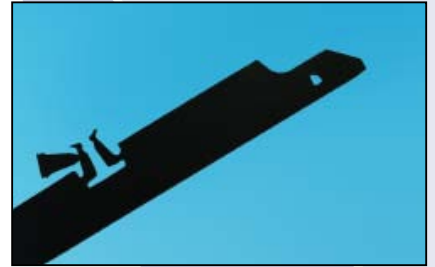

Stripping Pins



- ▶ Pointed
- ▶ Diameters of 2, 3, 4, 6, 8, 10, 12 and 14mm



- ▶ Flat
- ▶ Diameters of 2, 3, 4, 6, 8, 10, 12 and 14mm

Speedbar



- ▶ Available in widths of 9", 13" and 16"

Flush Presser



- ▶ Slots into dieboards

Rail for Flush Presser

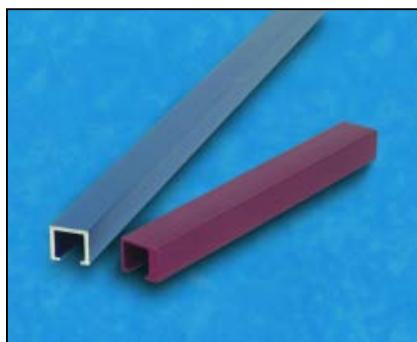

- ▶ Enables any length of presser to be created

Rear Lock



- ▶ Slot in for new style reinforcement bars

Perfix



- ▶ Two sizes available
 - 14mm high
 - 26mm high

Mounting Strip for Perfix

